



GAI-TRONICS®
A HUBBELL COMPANY

400-005 and 400-006 RigCom Stations

TABLE OF CONTENTS

<i>Confidentiality Notice</i>	1
<i>General Information</i>	1
<i>Important Safety Instructions</i>	2
<i>Installation</i>	2
Speaker Horn Assembly	3
Mounting	3
Hardware Configuration	3
Internal	3
External	3
Wiring	5
System Wiring	5
Station Wiring.....	5
System Line Balance.....	6
Field Connections	8
Cover Installation	10
<i>Operation</i>	10
Common Line System	11
Master/Slave System	11
<i>Maintenance</i>	12
F1/F2 Fuses	12
Troubleshooting	12
Replacement Parts and Accessories	13
<i>Specifications</i>	13
AC Power	13
DC Power	13
Amplifier PCBA	13
Speaker (Model 400-005 Only)	13
Mechanical	14
Environmental	14
<i>Approvals</i>	14
<i>Appendix A—Interfacing a Model 400-005 RigCom Station to EZ Page Stations</i>	14



GAI-TRONICS®
A HUBBELL COMPANY

400-005 and 400-006 RigCom Stations

Confidentiality Notice

This installation, operation, and maintenance manual contains sensitive business and technical information that is confidential and proprietary to GAI-Tronics. GAI-Tronics retains all intellectual property and other rights in or to the information contained herein. Use this information only in connection with the operation of your GAI-Tronics product or system. Do not disclose this manual in any form, in whole or in part, directly or indirectly, to any third party.

General Information

The GAI-Tronics Model 400-005 and 400-006 RigCom Stations are for use in a common-talk or a master/slave communication system. The stations' approvals are for the following hazardous locations when the installation is in accordance with GAI-Tronics Pub. 42004-562, RigCom UL Control Drawing No. 75614:

- Model 400-005: Class I, Div. 1, Groups C and D
- Model 400-006: Class I, Div. 1, Groups B, C, and D

The system provides push-to-talk, release-to-listen operation. Each station has a local on/off/volume control switch to activate and control the volume level at each station.

The Model 400-005 includes an attached speaker and driver unit. The Model 400-006 does not include the speaker and driver unit but does have a 1/2-inch NPT hole to remotely mount and connect the speaker driver unit to the station.

The RigCom stations have connections for an auxiliary microphone and footswitch for remote operation from the station. The auxiliary microphone replaces the speaker as the microphone and the auxiliary footswitch provides the same functionality as the push-to-talk switch.

NOTE: Using the auxiliary microphone and/or footswitch reduces the hazardous location approval to Class I, Div. 1, Group D.

The Model 400 Series RigCom stations operate with the EZ Page Series of GAI-Tronics equipment.

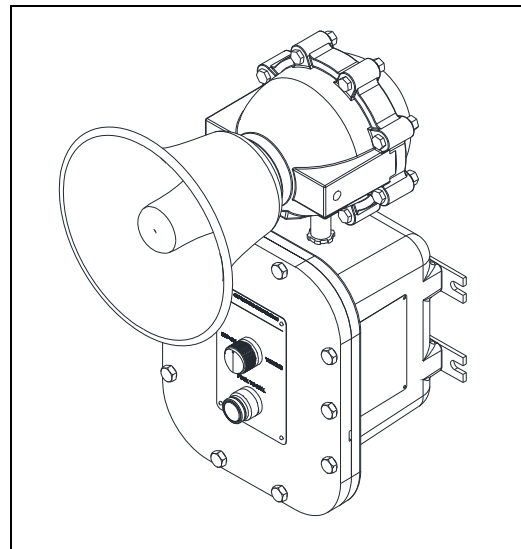







Figure 1. Model 400-005 RigCom Station



Safety Precautions

	CAUTION RISK OF ELECTRIC SHOCK. DO NOT OPEN!	
<p>CAUTION: TO REDUCE THE RISK OF ELECTRIC SHOCK, DO NOT REMOVE COVER (OR BACK). NO USER SERVICEABLE PARTS INSIDE. REFER SERVICING TO QUALIFIED SERVICE PERSONNEL.</p>		
	<p>This symbol indicates the presence of uninsulated “dangerous voltage” within the product’s enclosure. This may constitute a risk of electric shock.</p>	
	<p>The user should consult the operating and maintenance (servicing) instructions in the literature accompanying the appliance.</p>	
	<p>Attention: Installation should be performed by qualified service personnel only in accordance with the National Electrical Code or applicable local codes.</p>	

Important Safety Instructions

- **Read, follow, and retain instructions**—Read and follow all safety and operating instructions before installing or operating this unit. Retain instructions for future reference.
- **Heed warnings**—Adhere to all warnings on the unit and in the operating instructions.
- **Attachments**—Do not use attachments not recommended by the product manufacturer as they may cause hazards.



This permanently connected apparatus must have an ALL-POLE MAINS switch with a contact separation of at least 3 mm in each pole incorporated in the electrical installation of the building.

 **WARNING**  —To reduce the risk of fire or electrical shock, do not expose this apparatus to rain or moisture.

Installation

Only trained, qualified, and competent personnel shall install these enclosures. Installation must comply with state and national regulations, as well as safety practices for this type of equipment.

Install the Models 400-005 and 400-006 RigCom stations in accordance with GAI-Tronics Pub.42004-562, RigCom UL Control Drawing No. 75614.

 **CAUTION**  —Do not install this equipment in hazardous areas other than those indicated in the Approvals section of this manual. Such installation may cause a safety hazard and consequent injury or property damage.

The mounting location must be flat and provide proper clearance, rigidity, and strength to support the enclosure and all contained devices.

Securely fasten the enclosure to the mounting location using (customer-supplied) 7/16-inch diameter steel mounting bolts and washers, or washer head bolts.

 **WARNING**  —**Ensure proper grounding to protective earthing. Do not disconnect equipment while energized.**

Speaker Horn Assembly *(Model 400-005 Only)*

Assemble the Model 400-005 Speaker Horn Assembly prior to installation:

1. Unpack the unit.
2. Locate the speaker horn and driver unit.
3. Place the speaker bell over the driver bushing.
4. Position two large diameter fiber washers with the large diameter steel washer sandwiched between them on the speaker bushing.
5. Place the small diameter rubber washer into the speaker horn tip, followed by the small diameter fiber washer.
6. Screw the speaker horn tip to the driver bushing until it is snug.

Mounting

NOTE: The mounting surface must be able to support the weight of the aluminum enclosure. See the Specifications section for the weights and dimensions of the unit.

Securely fasten the enclosure with 7/16-inch diameter steel mounting bolts located on all four mounting feet (see Figure 2 for mounting dimensions).

Recommended: Use stainless steel hardware in corrosive environments.

Hardware Configuration

Internal

The enclosure contains a single PCBA, mounted in the rear of the enclosure. Make all customer connections to this PCBA. The front cover controls plug into the PCBA with a single wiring harness.

External

The enclosure contains a push-to-call button, an on-off/volume control switch, and applicable approval labeling. The enclosure has ten cover mounting bolts, located around the perimeter of the enclosure.

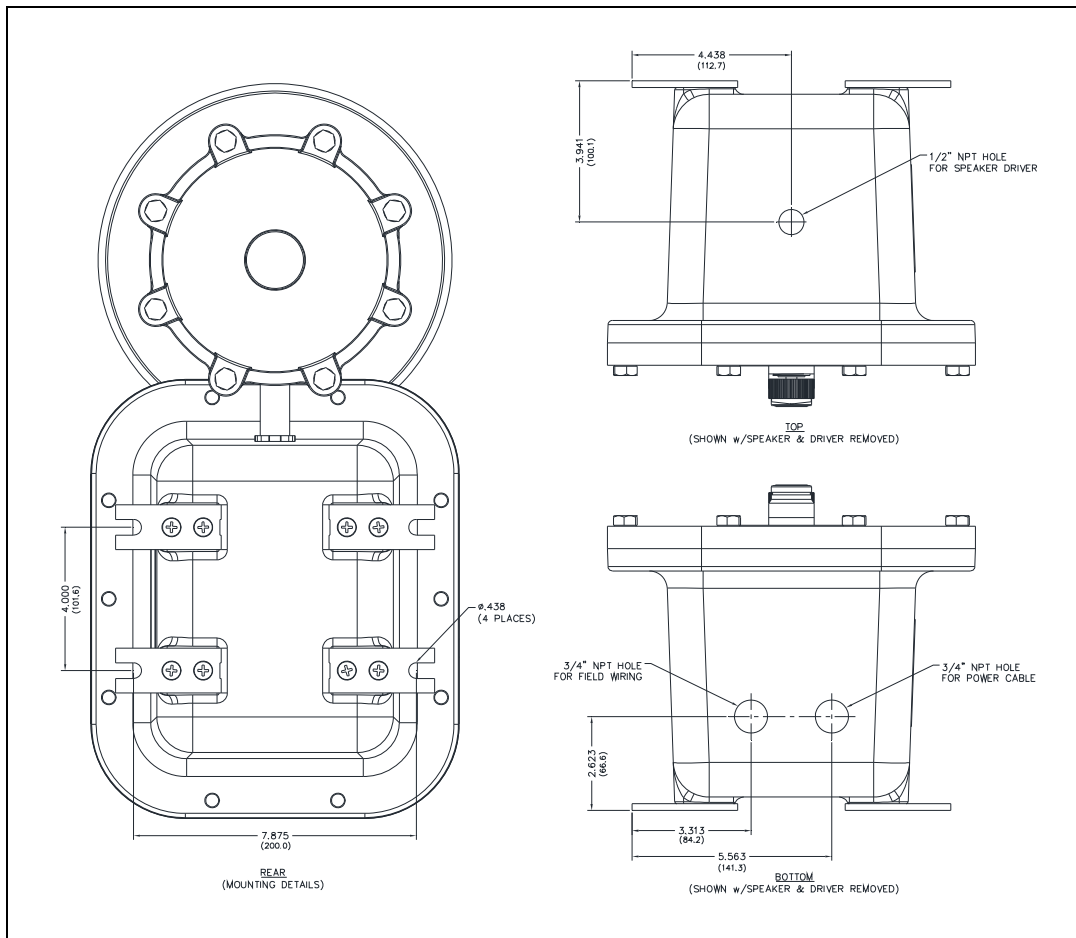

Figure 2. Model 400-005/400-006 Mounting Detail and Conduit Entries

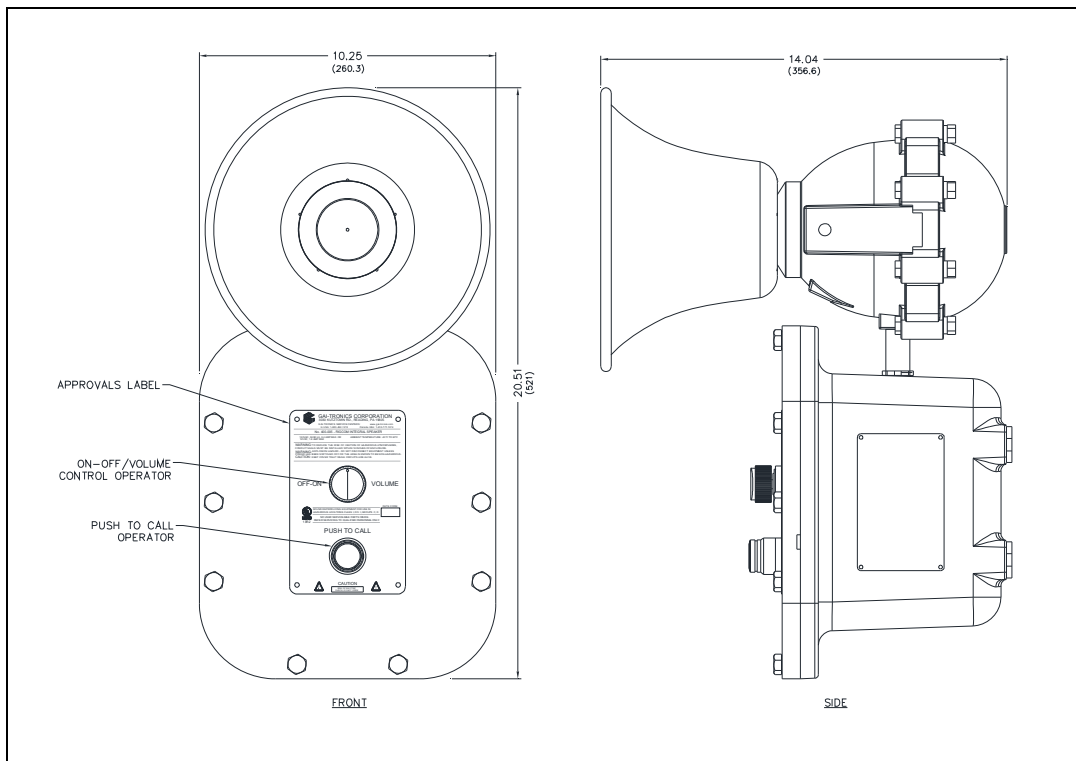

Figure 3. Model 400-005 RigCom Station Outline

Wiring

System Wiring

The maximum line length for the complete system, while still maintaining maximum output signal, is 15,000 feet for a system with less than ten stations; based on No. 18 AWG wire, equidistant station spacing, and one station in talk mode at a time. For each station in talk mode, the signal level reduces by half (see [Figure 4](#) for systems with more than ten stations to determine the maximum line distance).

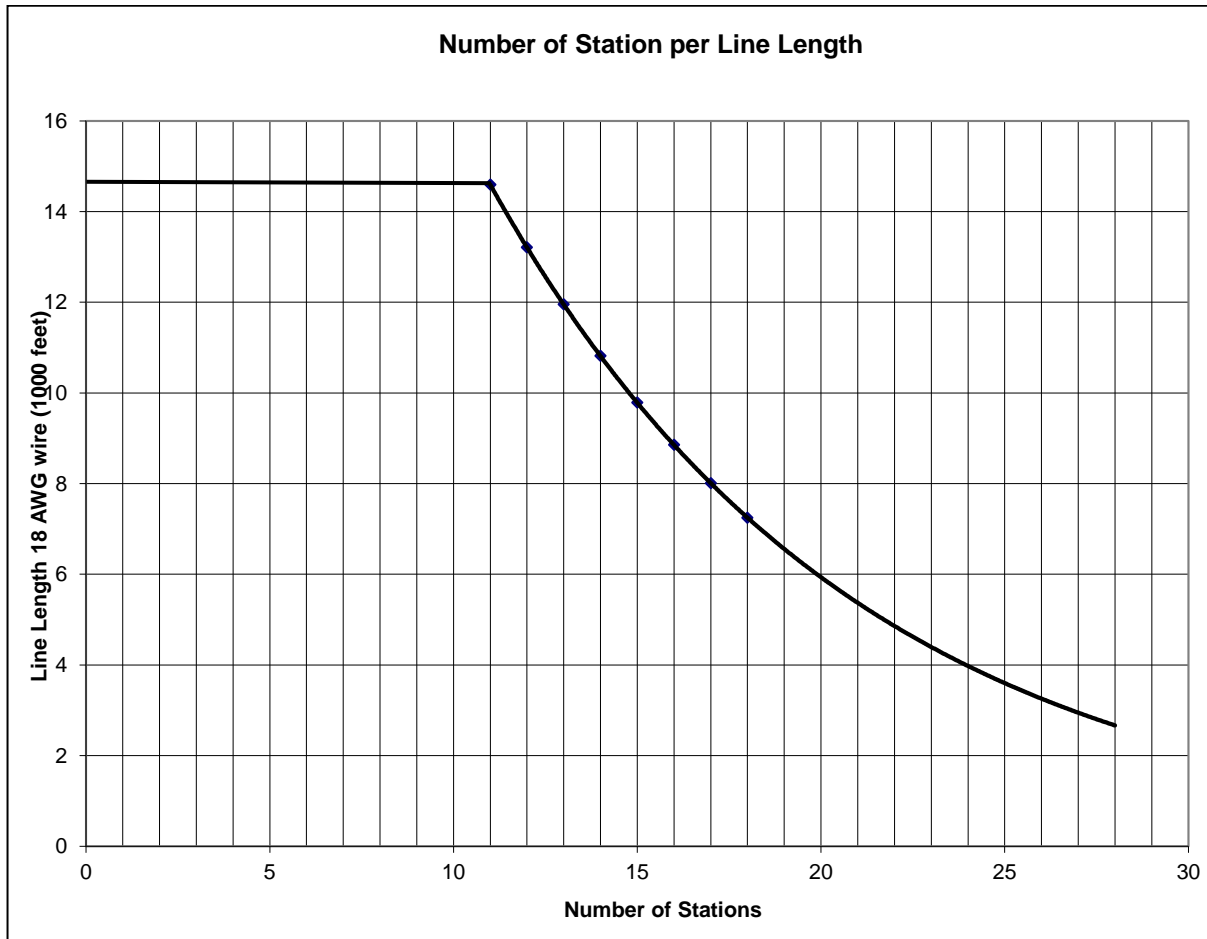

Figure 4. Number of Stations vs. Line Length

Station Wiring

1. Attach conduit or cable glands to the $\frac{3}{4}$ -inch NPT holes on the bottom of the enclosure.
2. Feed the low-voltage wiring through the conduit or cable gland and into the left-side hole, as viewed from the front of the station.
3. Feed the power wiring through the conduit or cable gland and into the right-side hole, as viewed from the front of the station.
4. *For ac power supply:*
 1. Install a #6 ring lug to the ground conductor
 2. Connect the ring lug on the ground wire to the ground terminal, located at the lower right corner of the RigCom station PCBA (see [Figure 5](#)).

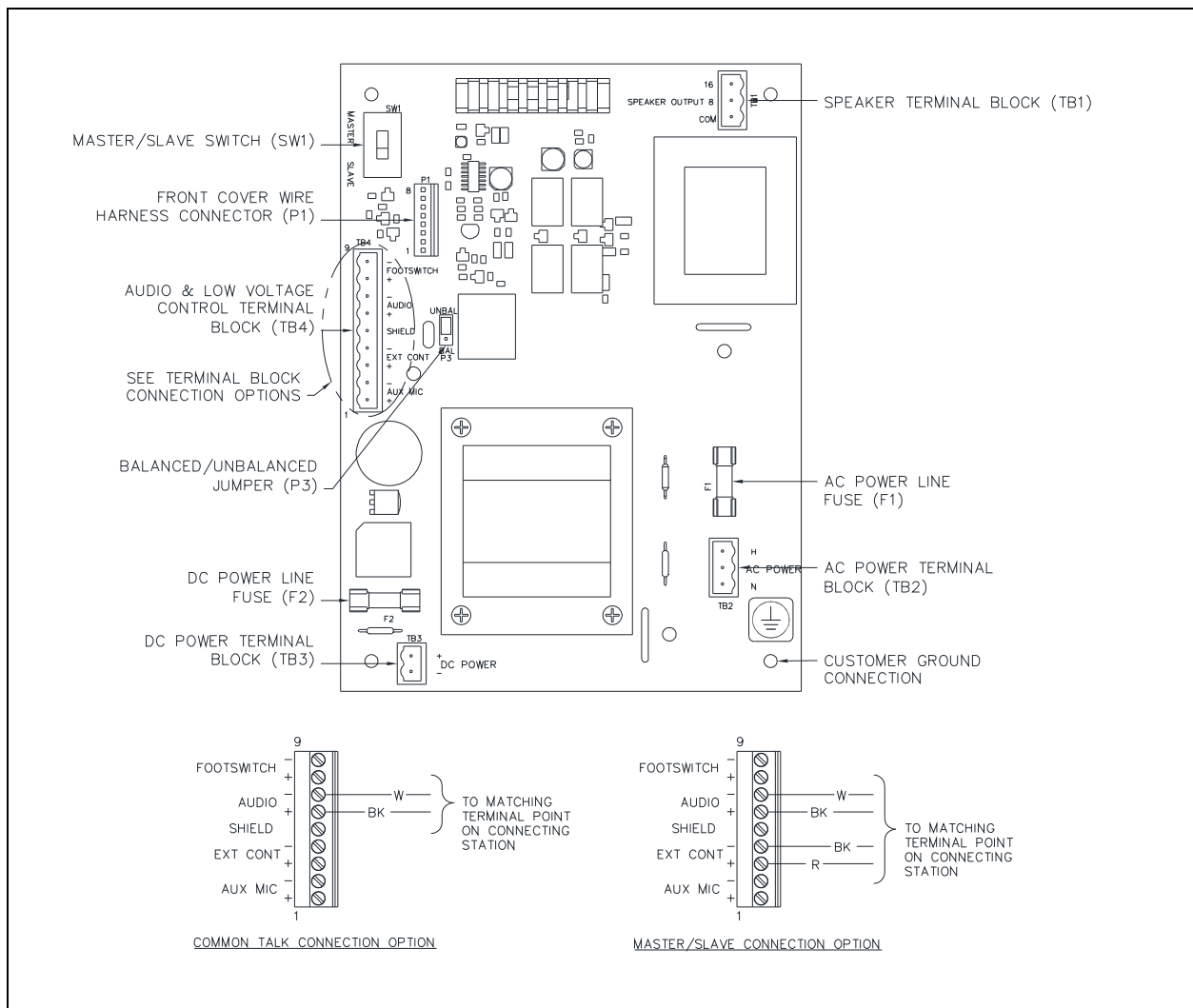

Figure 5. RigCom Station PCBA

5. Attach the wires to the terminal blocks, on the PCBA, within the enclosure (see [Figure 5](#) and the [Field Connections](#) section for connection points and descriptions).
6. *If using the 10438-002 Auxiliary Microphone Assembly:* Connect the assembly to the station at terminal block TB4-1 (+) and TB4-2 (-), and the shield to TB4-5, if used.
The maximum distance from the station is 50 feet using No. 18 AWG wire.
7. *If using the 51052-003 Auxiliary Footswitch Assembly:* Connect the assembly to the station at terminal block TB4-8 (+) and TB4-9 (-), and the shield to TB4-5, if used.
The maximum distance from the station is 50 feet using No. 18 AWG wire.

System Line Balance

Each system requires termination of the audio pair wires with a 1-kilohm, 1-watt resistor assembly, included with each unit. Install the line balance resistor assembly in a (*customer supplied*) junction box.

NOTE: Use only one line-balance resistor assembly per system.

Install the resistor assembly in a (*customer supplied*) junction box that is close to the center of the system when cable runs approximately 4000 feet (1219 m) or longer are used (see [Figure 6](#) and [Figure 7](#)).

NOTE: The junction box must be suitable for the applicable hazardous location where it is located.

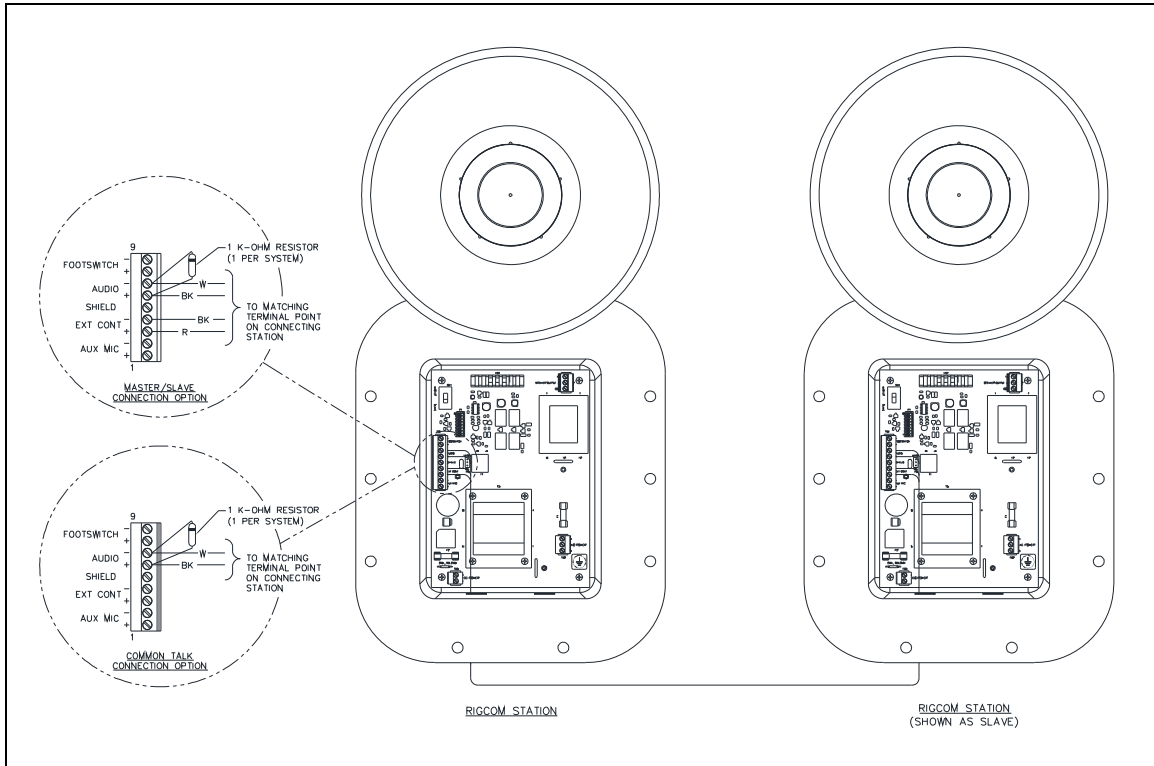

Figure 6. System Cable (wiring less than 4000 feet long)

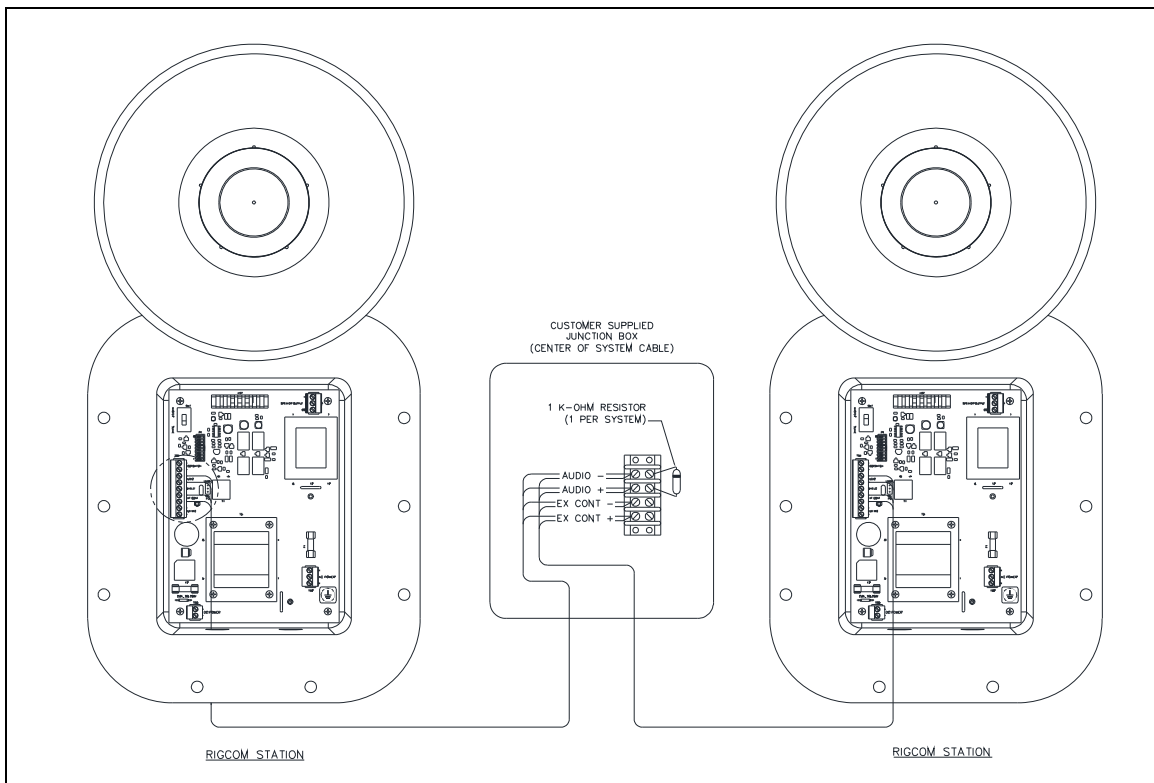

Figure 7. Master/Slave System (wiring greater than 4000 feet long)

Field Connections**TB1—Speaker Terminal Block**

Table 1. Speaker Output Connection at Terminal Block TB1

Name	Pin No.	Description
16	1	16-ohm terminal for external speaker connection
8	2	8-ohm terminal for external speaker connection
COM	3	common terminal for external speaker connection

TB2—AC Power Terminal Block

Table 2. AC Power Connection at Terminal Block TB2

Name	Pin No.	Description
AC POWER H	1	external ac power supply positive terminal no connection when using a dc power supply
	2	no connection
AC POWER N	3	external ac power supply neutral terminal no connection when using a dc power supply

AC POWER GND		ac ground conductor—Connect to the ground stud, located at the lower right corner of the station's PCBA.
-----------------	--	--

TB3—DC Power Terminal Block

Table 3. DC Power Connection at Terminal Block TB3

Name	Pin No.	Description
DC POWER INPUT+	2	external dc power supply positive terminal No connection when external dc power supply is not used.
DC POWER INPUT-	1	external dc power supply negative terminal no connection when not using an external dc power supply

TB4—Audio and Low Voltage Control Terminal Block

Table 4. Audio Signal and Low Voltage Control Connections at Terminal Block TB4

Name	Pin No.	Description
AUX MIC+	1	Positive terminal for the auxiliary microphone.
AUX MIC-	2	Negative terminal for the auxiliary microphone.
EXT CONT+	3	Talk/listen control signal for Master/Slave operation. No connection in Common Line mode.
EXT CONT-	4	Ground reference for talk/listen control signal for Master/Slave operation. No connection in Common Line mode or UNBAL audio configuration.
SHIELD	5	Ground reference for shield terminations.
AUDIO+	6	Positive side of the audio port line during 600-ohm or 15-kilohm termination configuration.
AUDIO-	7	Negative side of the audio page port line during 600-ohm or 15-kilohm termination configuration.
FOOTSWITCH+	8	Positive side of auxiliary footswitch that operates as the local push-to-talk switch.
FOOTSWITCH-	9	Negative side of auxiliary footswitch that operates as the local push-to-talk switch.

P1—Front Cover Wire Harness Connections

Plug the front cover wire harness connector in at P1 (see [Figure 5](#)).

P3—Balanced/Unbalanced Jumper

Jumper P3 allows configuration of the unit for balanced or unbalanced audio connections. Install the header in the BAL position for balanced audio input signals. Install the header in the UNBAL position to configure the assembly for unbalanced audio input signals.

NOTE: Configure the system as an unbalanced system when the external control signal is single-ended, such as previous GAI-Tronics Model MS39.xx RigCom stations.

SW1—Master/Slave Switch

Switch SW1 allows configuration of the unit as a master or slave unit. The switch must be in the MASTER position for common line operation.

- **Master**—Place switch SW1 in the MASTER position.
- **Slave**—Place switch SW1 in the SLAVE position.

Cover Installation

1. Inspect and clean the machined flange flame joint surfaces of both the cover and box.
Surfaces must be smooth, free of nicks, scratches, dirt, or any foreign particle build-up that may prevent a proper seal. Surfaces must seat fully against each other to provide a proper explosion-proof joint.
2. Clean the surfaces by wiping them with a clean lint-free cloth.
3. Apply a light coat of Killark LUBG lubricant to flange surfaces and close the cover.
4. Install all ten cover bolts.
Use only the bolts supplied with the enclosure. Do not omit any bolts.
5. Torque the cover bolts to 30 ft·lb (41 N·m).

NOTE: Refer to the Killark installation, operation and maintenance data sheet enclosed with the unit for additional information.

Operation

The station has an on-off/volume control switch and a push-to-talk switch.

1. Turn the unit on or off and adjust the volume level in the listen mode using the on-off/volume control switch.
2. Turn the unit off by turning the switch completely counterclockwise.
3. Turn the switch completely clockwise for maximum volume.

The push-to-talk switch controls the audio communication between stations.

1. Press the push-to-talk switch to send a message to another station.
2. Release the push-to talk switch to put the station in listen mode so that the station receives messages from other stations.

The push-to-talk switch is not functional on slave stations.

Common Line System

All stations are on a common audio path and are normally in listen mode in the common line configuration. Activation of a station's push-to-talk toggle switch supplies its audio signal to the common audio path. All other units receive the audio signal and broadcast the announcement over their speakers. Hold the *push-to-talk* switch down while talking. Release the switch to deactivate the microphone and return the unit to listen mode.

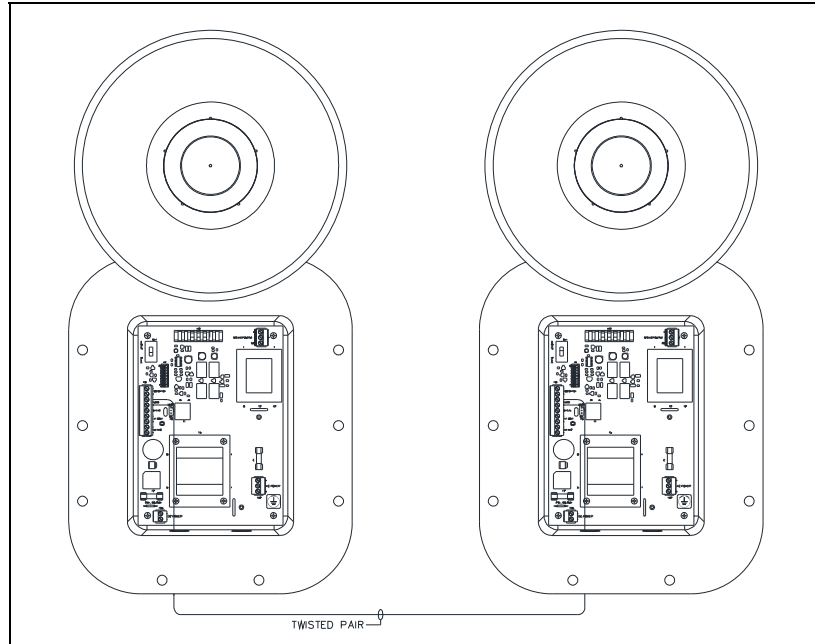

Figure 8. Common Talk Wiring Detail

Master/Slave System

A master station controls the talk-listen function of the slave units through external control wiring in the master/slave configuration. Slave stations are in talk mode allowing the master station to monitor the slave's audio when the master station is in listen mode (*push-to-talk not active*). Activate the master's push-to-talk toggle switch to place the slaves in listen mode, allowing the master to transmit audio to the slave stations. The push-to-talk switch is not functional on slave stations, making operation hands-free.

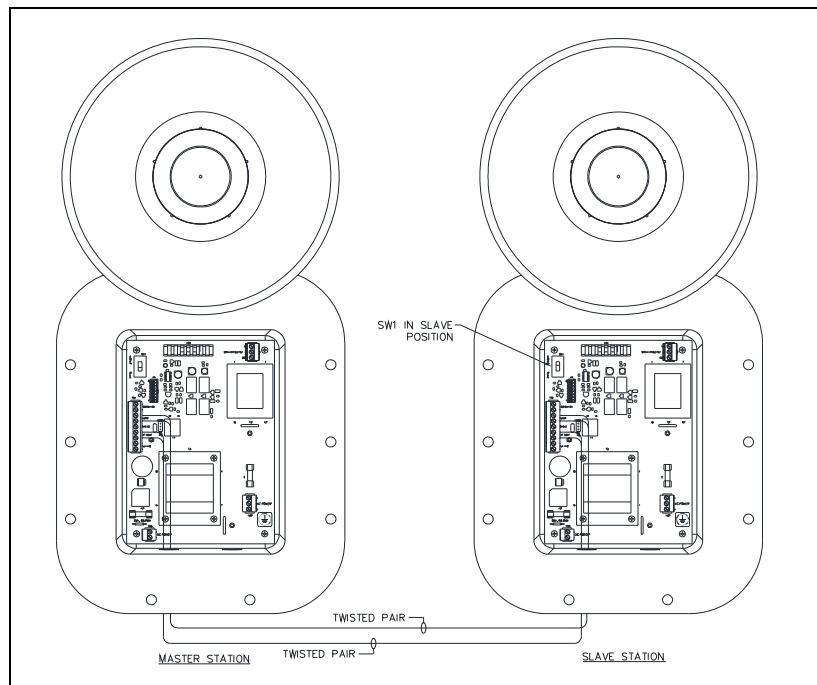



Figure 9. Master/Slave Wiring Detail



Maintenance



Contact a regional service center for a return authorization number (RA#) if the equipment requires service. Equipment must be shipped prepaid to GAI-Tronics with a return authorization number and a purchase order number. Repairs or a replacement will be made in accordance with GAI-Tronics' warranty policy if the equipment is under warranty. Please include a written explanation of all defects to assist our technicians in their troubleshooting efforts.

Call 800-492-1212 inside the USA or 610-777-1374 outside the USA for help identifying the Regional Service Center closest to you.



 **CAUTION**  —These servicing instructions are for use by qualified service personnel only. To reduce risk of electric shock, do not perform any servicing other than that contained in the Maintenance section unless you are qualified to do so.

Regular inspection and a good preventive maintenance program will increase the reliability of the GAI-Tronics station. The GAI-Tronics Field Service Department can formulate a service contract suited to specific needs for preventive maintenance.

 **WARNING**  —Before performing any of the following preventive maintenance steps, remove all power from the station.

 **CAUTION**  —To reduce the risk of ignition of hazardous atmospheres, disconnect the equipment from the supply circuit before making any adjustments to the PCBA's settings.

F1/F2 Fuses

 **WARNING**  —**Do not remove fuses when energized.**
Replace with the same type and size fuse for continued safe operation.

- Fuse F1—ac power line: 0.5 A, SLO-BLO, 250 V, 5×20 mm, UL.
- Fuse F2—dc power line: 2.0 A, SLO-BLO, 250 V, 5×20 mm, UL.

Troubleshooting

Problem	Solution
Any problem with station performance	Always review all steps of installation, ensuring that you correctly followed all steps. Check all terminations on the board.
Speaker volume needs adjustment	Adjust volume control. Replace speaker or driver.
Crosstalk	One or more system cable pairs may be improperly terminated. Visually inspect the system cable for accidental crossing of cable pairs or grounds.

Replacement Parts and Accessories

Contact GAI-Tronics for replacement part information.

Table 5. Available Accessories for RigCom Stations

Part No.	Description
12801-002	auxiliary microphone
51052-003	auxiliary footswitch
10438-002	microphone I.S. barrier kit (contains 12801-002 auxiliary mic assembly)
12807-001	connector kit
60075-001	audio cable, No. 18 AWG, (two-pair)

Specifications

AC Power

Voltage.....	120 V ac, 50/60 Hz
Power consumed (at nominal)	
Off (mute)	6 VA, 1.8 W
Standby	7.2 VA, 3.6 W
Maximum speaker out.....	30 VA, 27 W

DC Power

Voltage.....	12 V dc
Power consumed (at nominal)	
Off (mute)	0.3 W
Standby	3 W
Maximum speaker out.....	20 W

Amplifier PCBA

Frequency response.....	300 Hz–8 kHz, +/-3 dB
Audio output	8.0 W
Audio THD distortion	1% maximum, 8 W output
Hum/Noise	1% maximum, 8 W output
Gain—Listen mode.....	17 dB
Gain—Talk mode (speaker as the microphone)	42 dB
Gain—Talk mode (auxiliary microphone).....	48 dB

Speaker (Model 400-005 Only)

Rating.....	30 W maximum
Impedance	16 Ω
Frequency response.....	400 Hz–3.5 kHz, +/-6 dB
Sound pressure level, 1 W @ 1 m, swept sine wave.....	104 dB SPL

Mechanical

Construction/finish.....	cast aluminum/tumble finish
Mounting.....	wall or column, four 7/16-inch mounting feet with slots
Connections.....	plug-in style terminal blocks
Conduit entries	
bottom:	two, 3/4-inch NPT
top:	one, 1/2-inch NPT (Model 400-006 only)
Dimensions	20.5 H × 10.25 W × 14.21 D in (520.9 × 260.2 × 360.9 mm)
Shipping weight	
Model 400-005.....	40.0 lb (18.1 kg)
Model 400-006.....	27.0 lb (12.2 kg)

Environmental

Temperature range (operating and storage) -4 °F to +140 °F (-20 °C to +60 °C)

Approvals

The models below are approved for the following hazardous areas when installed in accordance with Pub. 42004-562, RigCom UL Control Drawing No. 75614.

Model 400-005 RigCom Station:

NRTL listed (USA)..... Hazardous locations Class I, Div. 1, Groups C & D
 When using auxiliary microphone and/or footswitch: Hazardous locations Class I, Div. 1, Group D

Model 400-006 RigCom Station:

NRTL listed (USA)..... Hazardous locations Class I, Div. 1, Groups B, C & D
 When using auxiliary microphone and/or footswitch: Hazardous locations Class I, Div. 1, Group D

Appendix A—Interfacing a Model 400-005 RigCom Station to EZ Page Stations

The Model 400-005 RigCom Station operates as an addition to a system of EZ Page stations.

The EZ Page Series and Model 400-005 Stations operate in either balanced or unbalanced systems. An unbalanced communication system uses the negative of the audio pair as the ground reference for the control signal. The audio pair is not ground referenced in a balanced system and the control signal requires a separate ground signal.

Configure the Model 400-005 RigCom stations and the EZ Page stations identically as balanced or unbalanced using jumper P3 on the Model 400-005 station(s) and jumper P5 on the EZ Page station(s) for interoperability between the Model 400-005 RigCom and the EZ Page Series stations.

The following are wiring diagrams are for the different configurations of a RigCom/EZ Page system:

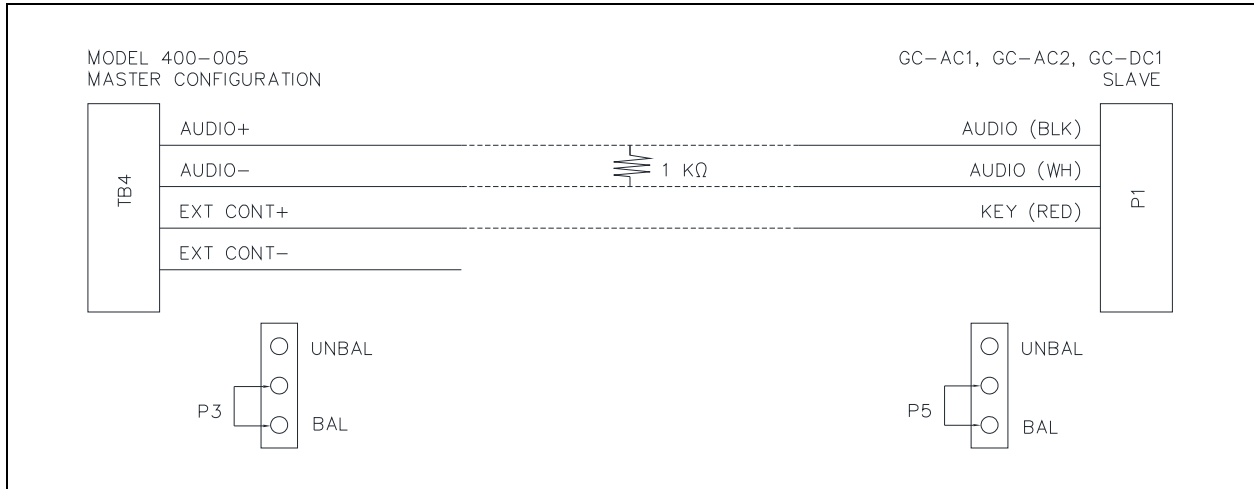

Figure 10. Master/Slave Unbalanced Configuration with the Model 400-005 as Master

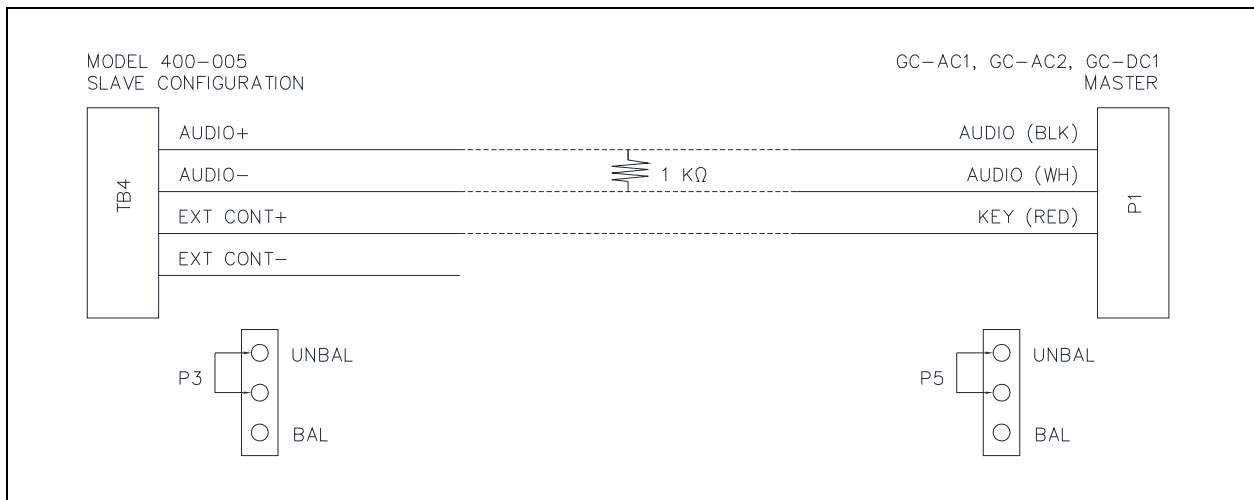

Figure 11. Master/Slave Unbalanced Configuration with the Model 400-005 as Slave



Figure 12. Unbalanced Common Line Configuration

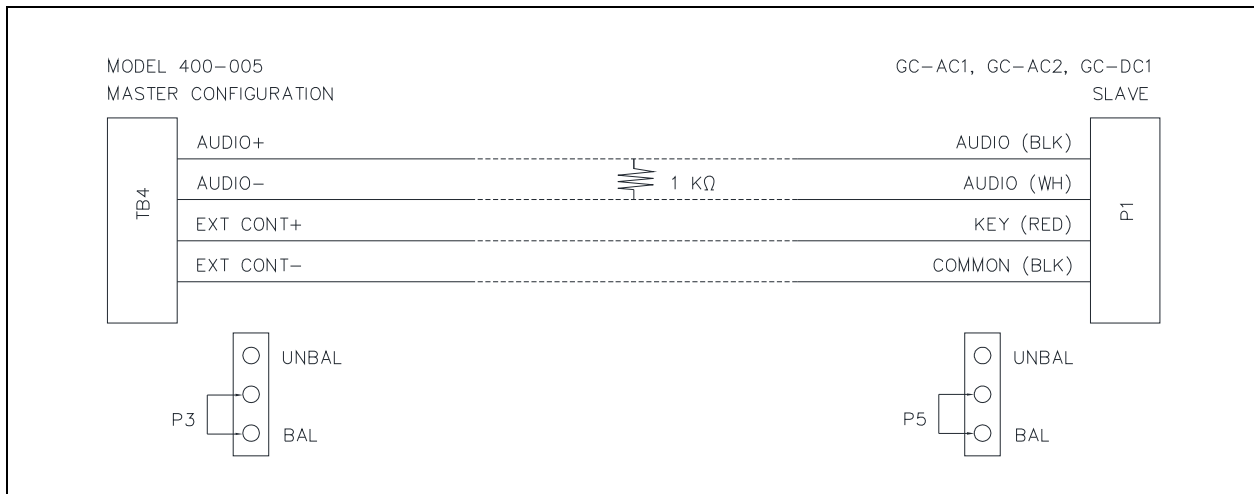

Figure 13. Master/Slave Balanced Configuration with Model 400-005 as Master

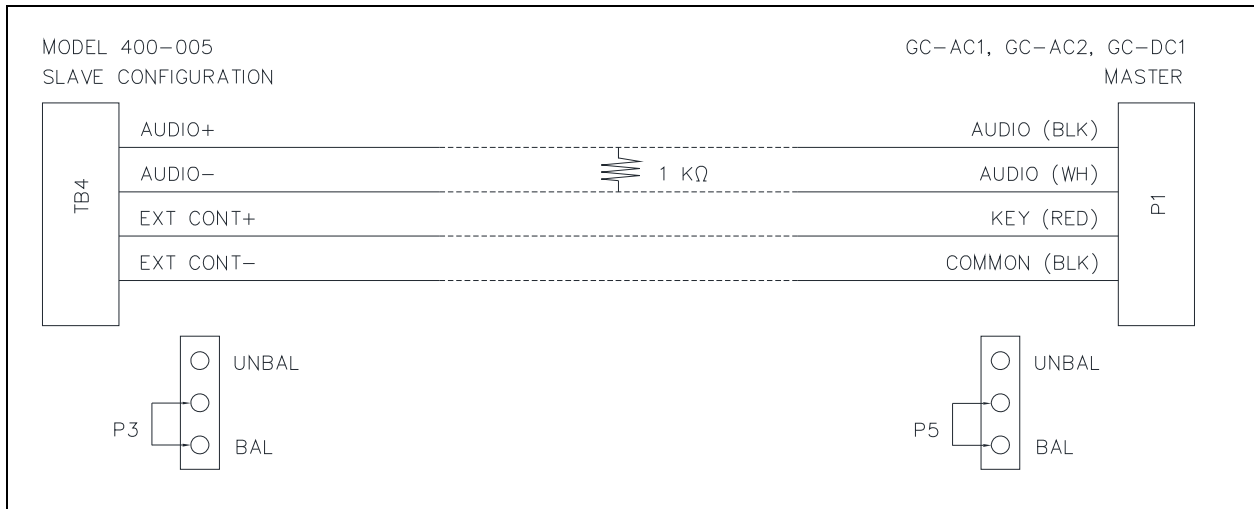

Figure 14. Master/Slave Balanced Configuration with Model 400-005 as Slave

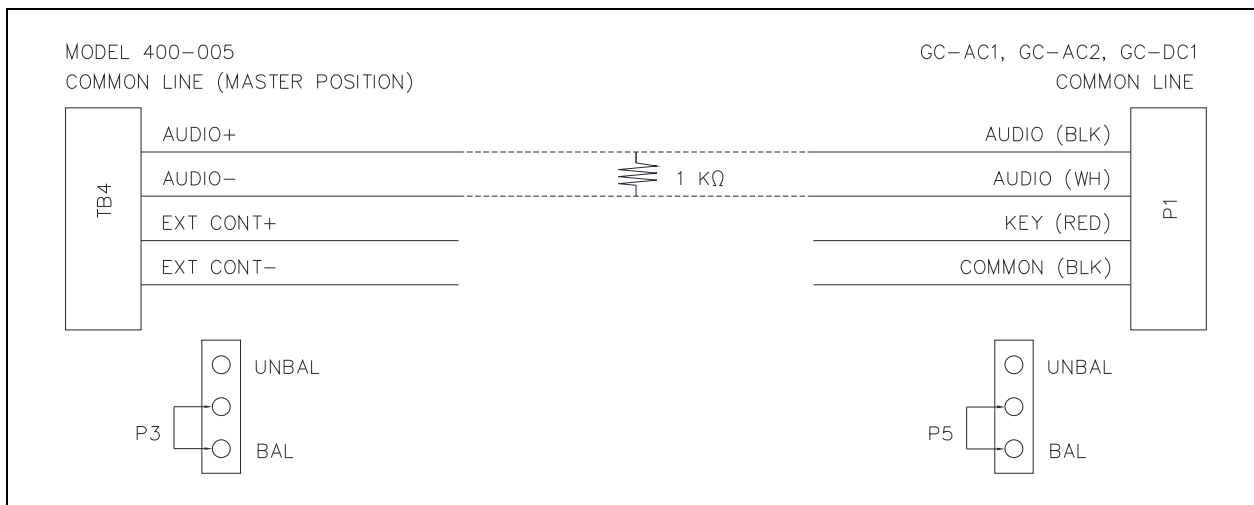

Figure 15. Balanced Common Line Configuration

Warranty

Equipment. GAI-Tronics warrants for a period of one (1) year from the date of shipment, that any GAI-Tronics equipment supplied hereunder shall be free of defects in material and workmanship, shall comply with the then-current product specifications and product literature, and if applicable, shall be fit for the purpose specified in the agreed-upon quotation or proposal document. If (a) Seller's goods prove to be defective in workmanship and/or material under normal and proper usage, or unfit for the purpose specified and agreed upon, and (b) Buyer's claim is made within the warranty period set forth above, Buyer may return such goods to GAI-Tronics' nearest depot repair facility, freight prepaid, at which time they will be repaired or replaced, at Seller's option, without charge to Buyer. Repair or replacement shall be Buyer's sole and exclusive remedy. The warranty period on any repaired or replacement equipment shall be the greater of the ninety (90) day repair warranty or one (1) year from the date the original equipment was shipped. In no event shall GAI-Tronics warranty obligations with respect to equipment exceed 100% of the total cost of the equipment supplied hereunder. Buyer may also be entitled to the manufacturer's warranty on any third-party goods supplied by GAI-Tronics hereunder. The applicability of any such third-party warranty will be determined by GAI-Tronics.

Services. Any services GAI-Tronics provides hereunder, whether directly or through subcontractors, shall be performed in accordance with the standard of care with which such services are normally provided in the industry. If the services fail to meet the applicable industry standard, GAI-Tronics will re-perform such services at no cost to buyer to correct said deficiency to Company's satisfaction provided any and all issues are identified prior to the demobilization of the Contractor's personnel from the work site. Re-performance of services shall be Buyer's sole and exclusive remedy, and in no event shall GAI-Tronics warranty obligations with respect to services exceed 100% of the total cost of the services provided hereunder.

Warranty Periods. Every claim by Buyer alleging a defect in the goods and/or services provided hereunder shall be deemed waived unless such claim is made in writing within the applicable warranty periods as set forth above. Provided, however, that if the defect complained of is latent and not discoverable within the above warranty periods, every claim arising on account of such latent defect shall be deemed waived unless it is made in writing within a reasonable time after such latent defect is or should have been discovered by Buyer.

Limitations / Exclusions. The warranties herein shall not apply to, and GAI-Tronics shall not be responsible for, any damage to the goods or failure of the services supplied hereunder, to the extent caused by Buyer's neglect, failure to follow operational and maintenance procedures provided with the equipment, or the use of technicians not specifically authorized by GAI-Tronics to maintain or service the equipment. **THE WARRANTIES AND REMEDIES CONTAINED HEREIN ARE IN LIEU OF AND EXCLUDE ALL OTHER WARRANTIES AND REMEDIES, WHETHER EXPRESS OR IMPLIED BY OPERATION OF LAW OR OTHERWISE, INCLUDING ANY WARRANTIES OF MERCHANTABILITY OR FITNESS FOR A PARTICULAR PURPOSE.**

Return Policy

If the equipment requires service, contact your Regional Service Center for a return authorization number (RA#). Equipment should be shipped prepaid to GAI-Tronics with a return authorization number and a purchase order number. If the equipment is under warranty, repairs or a replacement will be made in accordance with the warranty policy set forth above. Please include a written explanation of all defects to assist our technicians in their troubleshooting efforts.

Call 800-492-1212 (inside the USA) or 610-777-1374 (outside the USA) for help identifying the Regional Service Center closest to you.